

Instructions:

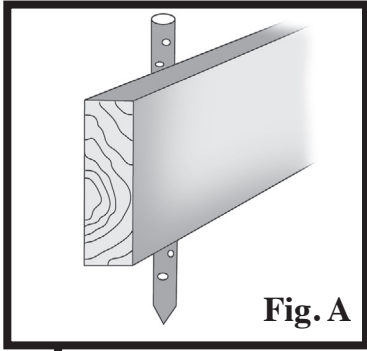

Fig. A

Form Setting Requirements

All formwork must be set and braced in advance establishing the desired run and rise of the steps to be poured. See Fig. A

Choosing a Riser height

Step Liners are provided with “break-away” cuts that allow a choice of riser height. See Fig. B

Note: When using the “break-away” a sanding block is useful to smooth the bottom edge of the Step Liner form.

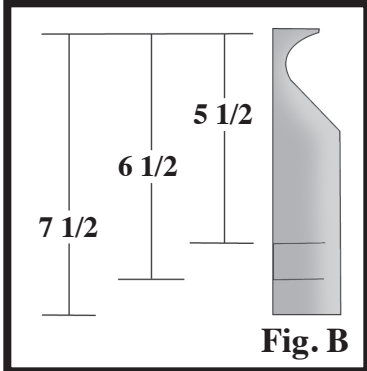

Fig. B

Setting the Form

Nailing Method Holding the Step Liner flush with the top of the form work, press finish nails (no heads) through the Step Liner and carefully tape flush.

Spray Adhesive Method Spray the surface of the wood form as well as the Step Liner and allow to dry to a tacky consistency. Press the Step Liner to the inside of the wood form, flush with the top. See Fig. C

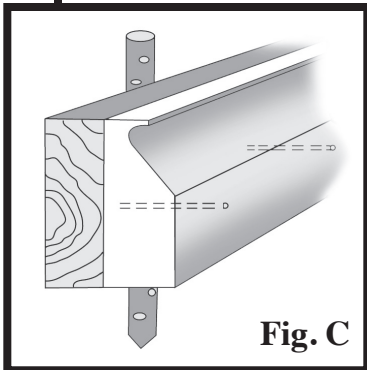

Fig. C

Pouring

Be sure to tap or vibrate the form while pouring to eliminate any rock pockets or “honeycomb.” See Fig. D

Stripping/Finishing

Once the concrete is strong enough to support its own weight, the forms can be removed. Remove all stakes and bracing first. Slide a margin trowel between the wood form and the Step Liner and remove the wood form. Peel the Step Liner form away from the concrete, exposing the edge to be finished. See Fig. E

Note: Removing the forms one section at a time retains moisture in the surface, allowing adequate time to finish the concrete.

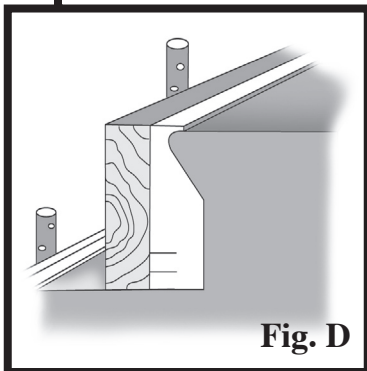

Fig. D

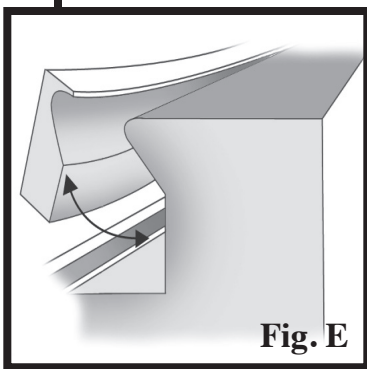

Fig. E

040412

