

6" Capstone Form

Tech Support (800) 382-5430

Instructions:

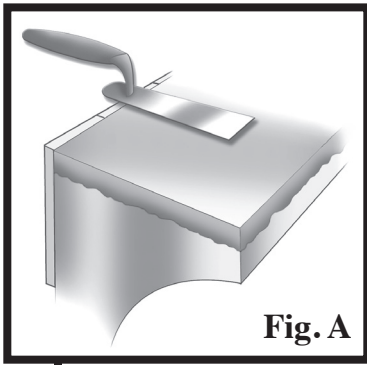

Fig. A

Tile Setting Requirements

Tile must be set from the high point of the bond beam and bedded out level. Scrape the top of the tile to remove any debris that would cause the tile strip to fit unevenly around the perimeter. See Fig. A

Setting the Form

Peel the paper from the double faced tape (one foot at a time) and stick the form to the tile with the bottom of the decorative profile edge level with the top of the tile. *The tile must be clean and free of dust before setting the form.* See Fig. B

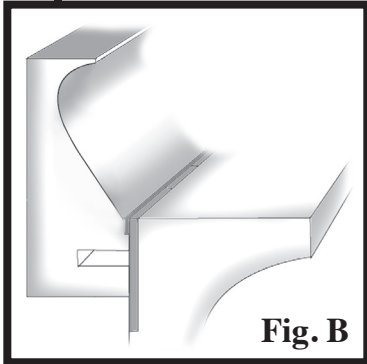

Fig. B

Bending Instructions: Detailed form bending instructions are included with the Tie Wire Side Kit.

Note: During cold weather it may be necessary to warm the tile with a heat gun just prior to sticking the form.

Placing the Tile Strip

Insert the tile strip into the notch provided in the form, making sure it is pressed down tight to the tile. Be sure to butt the joints together, as this strip will be visible in the finished product. See Fig. C

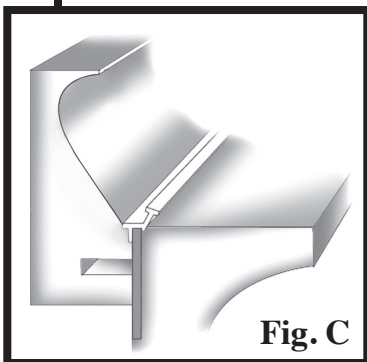

Fig. C

Bond Breaker

Cover the top of the bond beam with 15 lb. felt to act as a “bond breaker,” allowing the concrete deck to expand and contract without disturbing the tile. See Fig. D

Placing the Tie Wires

Drive the concrete nails (provided) into the bond beam 6 inches apart, 8 inches back from the tile. Be sure to leave the tops of the nails exposed to attach the tie wires. Push the tie wires through the form, level with the top of the tile strip, applying pressure while wrapping securely around the nails. See Fig. D

Note: In addition to bracing the form, the tie wires also insure that the tile strip stays securely in place.

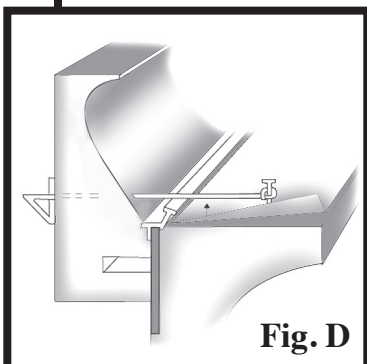

Fig. D

Pouring

Be sure to tap or vibrate the form while pouring to help eliminate any rock pockets or “honeycomb.”

Stripping / Finishing

Once the concrete is strong enough to support its own weight, the forms can be removed. Remove the tie wires by twisting the “pig tail,” severing the tie wires below the surface of the concrete. See Fig. E

Note: Removing the forms one section at a time retains moisture in the surface, allowing adequate time to finish the concrete.

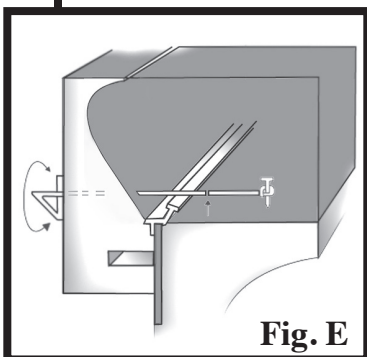

Fig. E

Patented

091117

STEGMEIER
LLC
www.stegmeier.com
Since 1968

IMPORTANT

**Break off and Discard
Top edge protector
Before using forms**

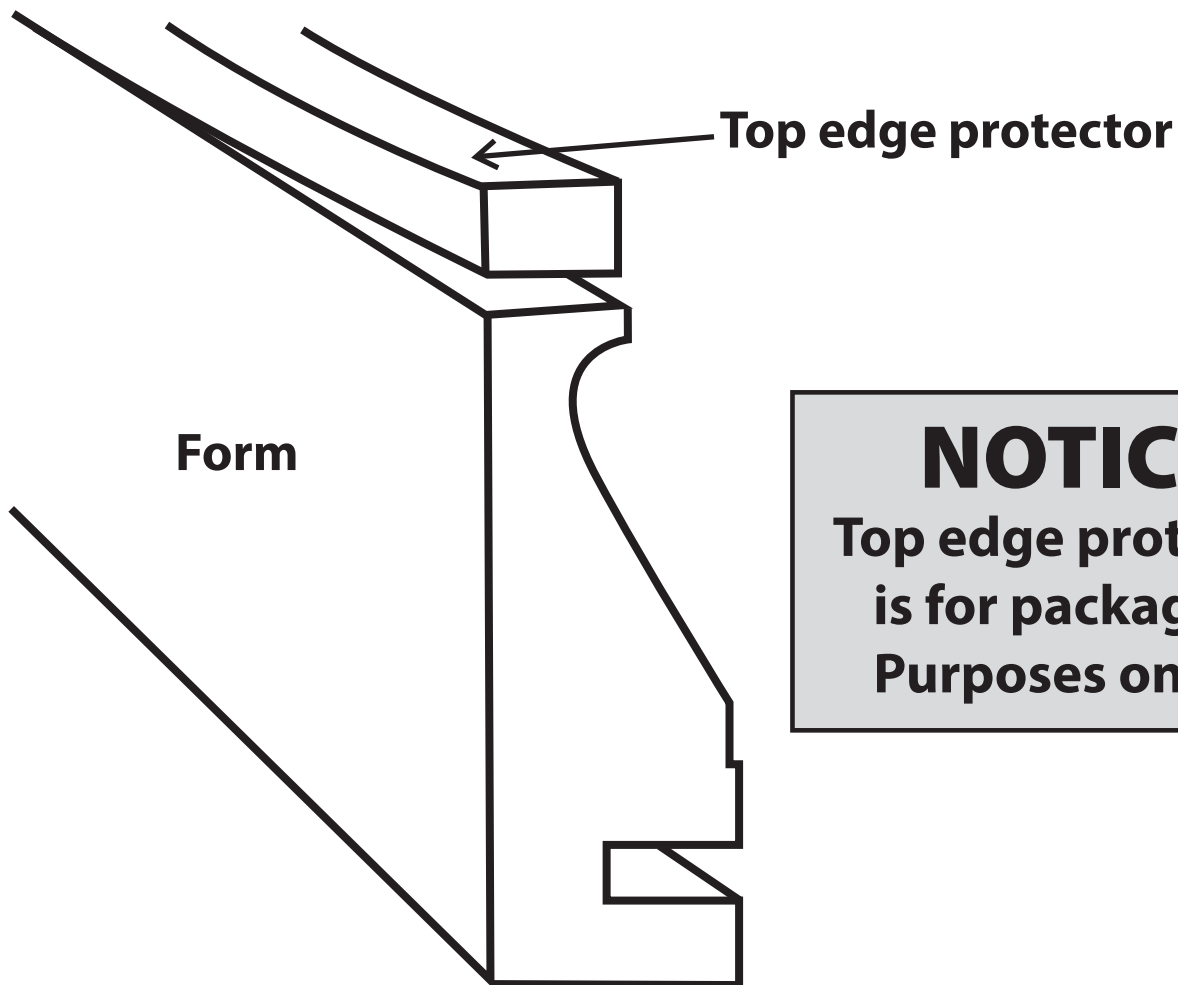

NOTICE

**Top edge protector
is for packaging
Purposes only!!!**

STEGMEIER
LLC



www.stegmeier.com

Since 1968

1111 W. Harris Road, Arlington, TX 76001

Phone: (800) 382-5430 Fax: (800) 356-3602