

# Fiberglass Pool Forms with Plumb Strip

**STEGMEIER**  
LLC

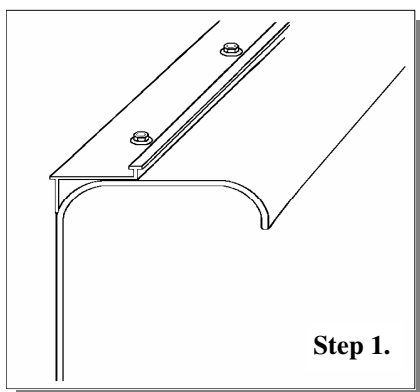

**Step 1.** Lay the plumb strip level on the edge of the wall. Use screws to fasten down the strip. Be sure to butt the joints tightly together as the strip will be visible in the finished product.

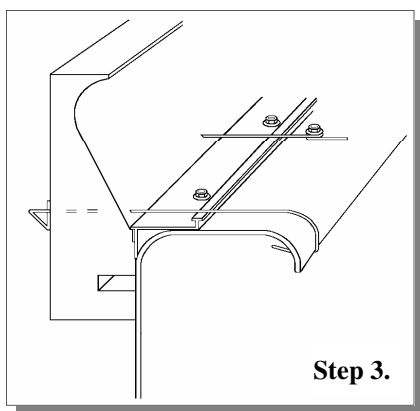

**Step 2.** Peel the paper from the double-face tape (one foot at a time) sticking the form to the plumb strip and sidewall, with the lower edge of the form profile even with the top of the plumbstrip.

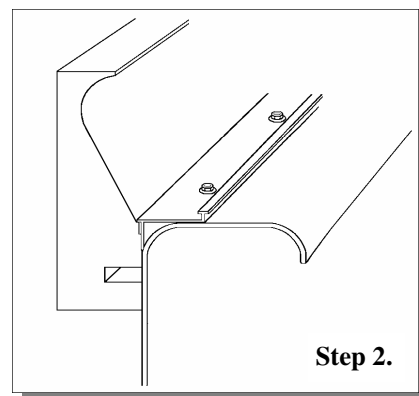

*Note: During cold weather it may be necessary to warm the pool wall and plumb strip prior to sticking the form.*

*Note: The tie wires can be fastened one of two ways. They can be wrapped around the back lip of the wall or you can use the other (100) self tapping screws. To use the screws, just fasten them 4" behind the plumb strip (only half way down and wrap the tail of the tie wire around them.*

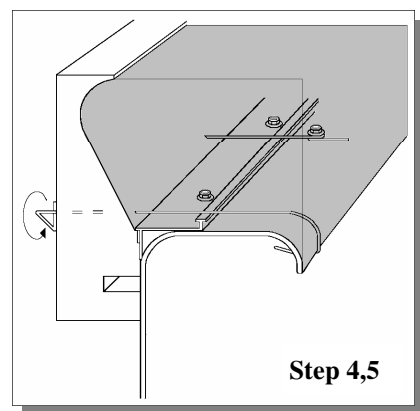

**Step 3.** Push the tie wire through the form, even with the top of plumb strip. wrap the end of the tie wire around the back lip of the wall or screw, applying slight pressure.

**Step 4.** While pouring tap the form to release air bubbles. This will help prevent honeycombing.

**Step 5.** When the concrete is strong enough to support it's own weight, the forms can be removed. To remove the forms, twist the tie wire head, it will break the tie wire inside the concrete. Then pull the form away exposing the face for the finish.

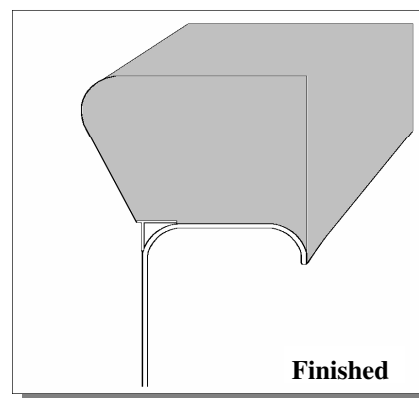

As conditions and methods of use of our products are beyond our control, we offer these products in good faith but without guarantee either expressed or implied.